

Computer Networks and Communications

Lecture (06):

Multiplexing

Multiplexing

- **Multiplexing:**
 - Combining multiple data (voice) channels for transmission on a common medium.
 - Allows several transmission sources to share a larger transmission capacity.
- **Demultiplexing:**
 - Recovering the original channels from a multiplexed signal.
- **Frequency division multiplexing (FDM) and time division multiplexing (TDM).**



Frequency Division Multiplexing

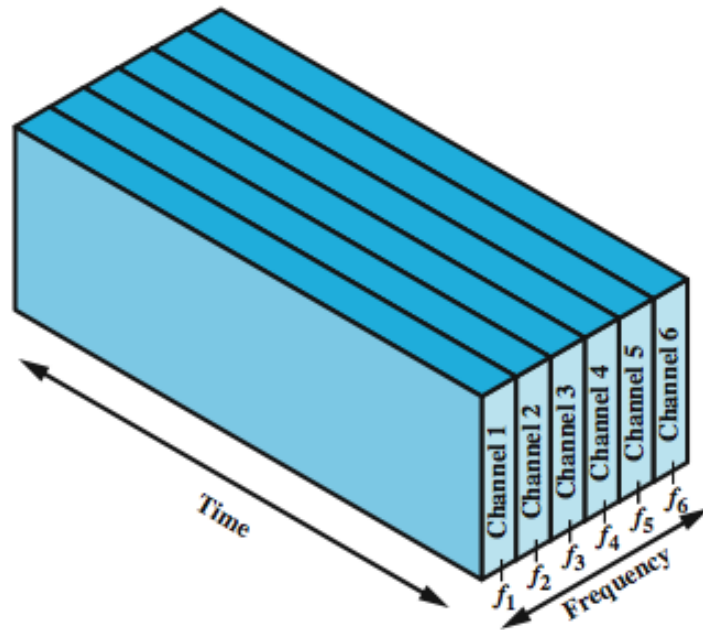

(a) Frequency division multiplexing

FDM System Overview

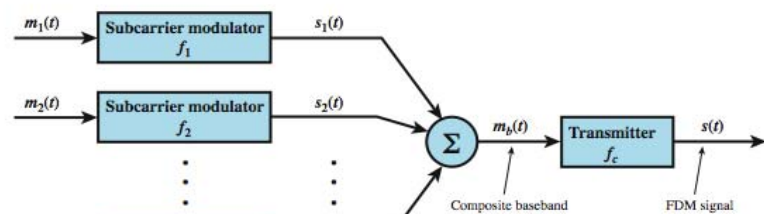

(a) Transmitter

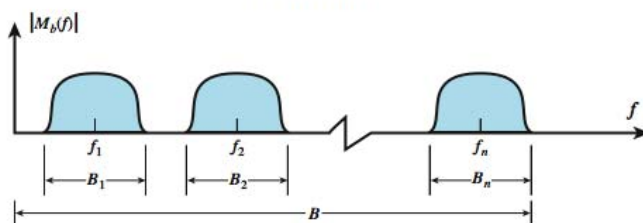

(b) Spectrum of composite baseband modulating signal

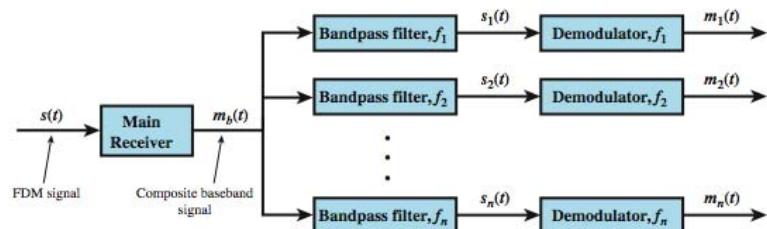

(c) Receiver

FDM Voiceband Example

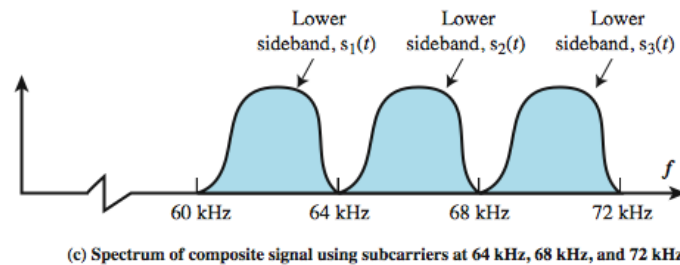
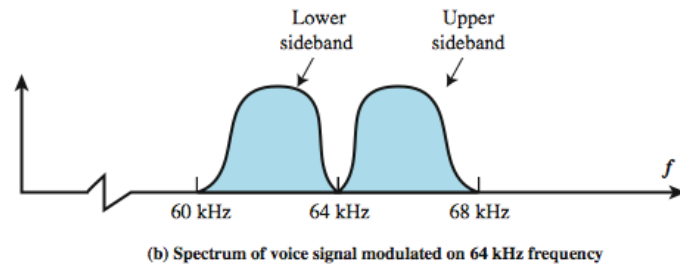
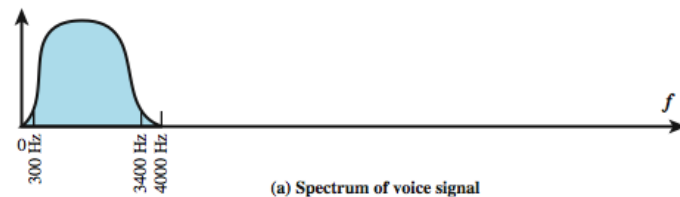

Analog Carrier Systems

- Long distance voiceband signals over high-capacity transmission links (coaxial and microwave).
- Hierarchy of FDM schemes by AT&T (USA) and ITU-T (international).

No. of voice channels	Bandwidth	Spectrum	AT&T	ITU-T
12	48 kHz	60-108 kHz	Group	Group
60	240 kHz	312-552 kHz	Supergroup	Supergroup
300	1.232 MHz	812-2044 kHz		Mastergroup
600	2.52 MHz	564-3084 kHz	Mastergroup	

Synchronous Time Division Multiplexing

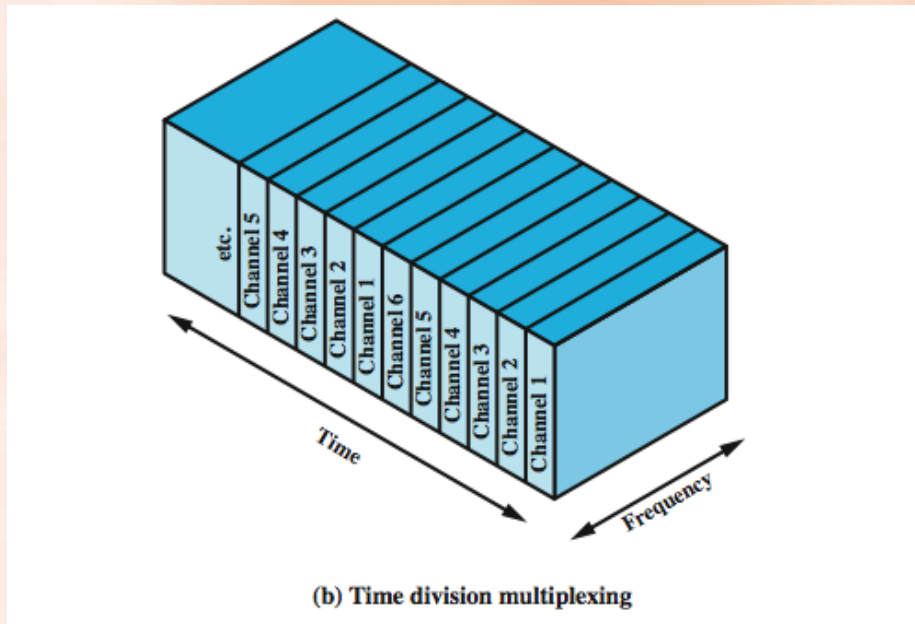

TDM System Overview

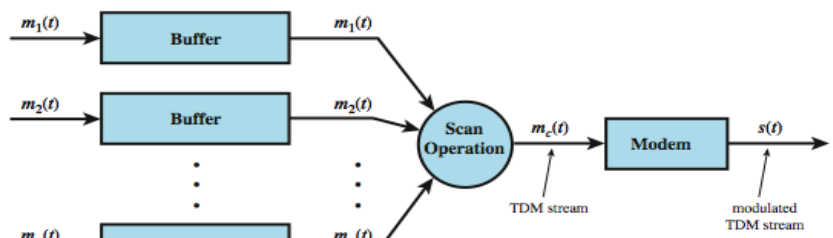

(a) Transmitter

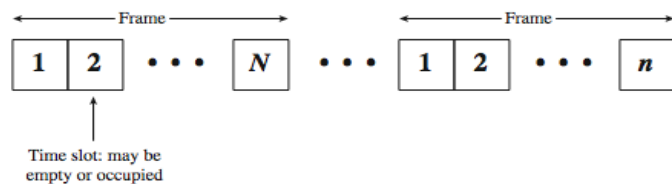

(b) TDM Frames

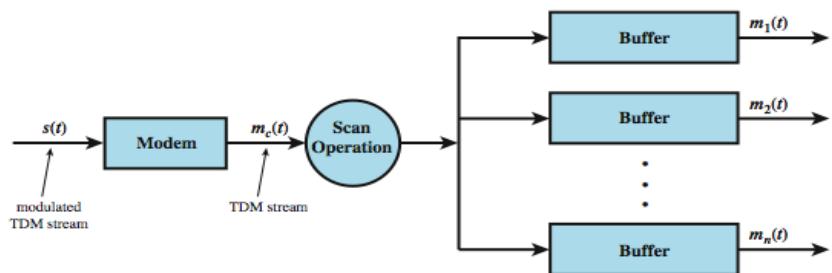

(c) Receiver

TDM Link Control

- no headers and trailers
- data link control protocols not needed
- flow control
 - data rate of multiplexed line is fixed
 - if one channel receiver can not receive data, the others must carry on
 - corresponding source must be quenched
 - leaving empty slots
- error control
 - errors detected & handled on individual channel

Data Link Control on TDM



(a) Configuration

Input₁..... F₁ f₁ f₁ d₁ d₁ d₁ C₁ A₁ F₁ f₁ f₁ d₁ d₁ d₁ C₁ A₁ F₁
 Input₂... F₂ f₂ f₂ d₂ d₂ d₂ d₂ C₂ A₂ F₂ f₂ f₂ d₂ d₂ d₂ d₂ C₂ A₂ F₂

(b) Input data streams

... f₂ F₁ d₂ f₁ d₂ f₁ d₂ d₁ d₂ d₁ C₂ d₁ A₂ C₁ F₂ A₁ f₂ F₁ f₂ f₁ d₂ f₁ d₂ d₁ d₂ d₁ d₂ d₁ d₂ d₁ C₂ C₁ A₂ A₁ F₂ F₁

(c) Multiplexed data stream

Legend: F = flag field d = one octet of data field
 A = address field f = one octet of FCS field
 C = control field

Framing

- no flag or SYNC chars bracketing TDM frames
- must still provide synchronizing mechanism between src and dest clocks
- added digit framing
 - one control bit added to each TDM frame
 - identifiable bit pattern used on control channel
 - eg. alternating 01010101...unlikely on a data channel
 - compare incoming bit patterns on each channel with known sync pattern

Pulse Stuffing

- have problem of synchronizing data sources
- with clocks in different sources drifting
- also issue of data rates from different sources not related by simple rational number
- Pulse Stuffing a common solution
 - have outgoing data rate (excluding framing bits) higher than sum of incoming rates
 - stuff extra dummy bits or pulses into each incoming signal until it matches local clock
 - stuffed pulses inserted at fixed locations in frame and removed at demultiplexer

TDM Example

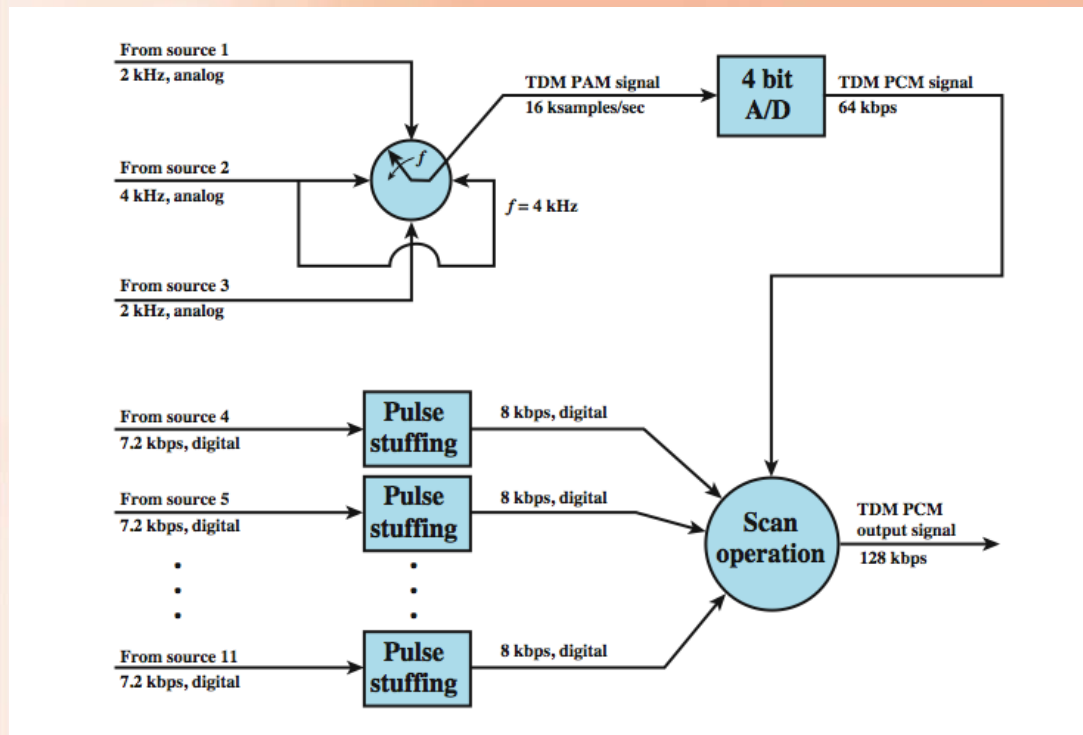

Digital Carrier Systems

- long-distance links use an TDM hierarchy
- AT&T (USA) and ITU-T (International) variants
- US system based on DS-1 format
- can carry mixed voice and data signals
- 24 channels used for total data rate 1.544Mbps
- each voice channel contains one word of digitized data (PCM, 8000 samples per sec)
- same format for 56kbps digital data
- can interleave DS-1 channels for higher rates
 - DS-2 is four DS-1 at 6.312Mbps

DS-1 Transmission Format

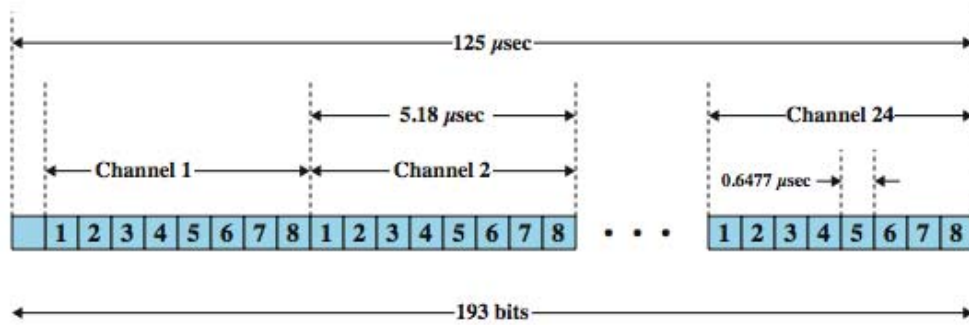

Notes:

1. The first bit is a framing bit, used for synchronization.
2. Voice channels:
 - 8-bit PCM used on five of six frames.
 - 7-bit PCM used on every sixth frame; bit 8 of each channel is a signaling bit.
3. Data channels:
 - Channel 24 is used for signaling only in some schemes.
 - Bits 1-7 used for 56 kbps service
 - Bits 2-7 used for 9.6, 4.8, and 2.4 kbps service.

SONET/SDH

- Synchronous Optical Network (ANSI)
- Synchronous Digital Hierarchy (ITU-T)
- have hierarchy of signal rates
 - Synchronous Transport Signal level 1 (STS-1) or Optical Carrier level 1 (OC-1) is 51.84Mbps
 - carries one DS-3 or multiple (DS1 DS1C DS2) plus ITU-T rates (eg. 2.048Mbps)
 - multiple STS-1 combine into STS-N signal
 - ITU-T lowest rate is 155.52Mbps (STM-1)

SONET Frame Format

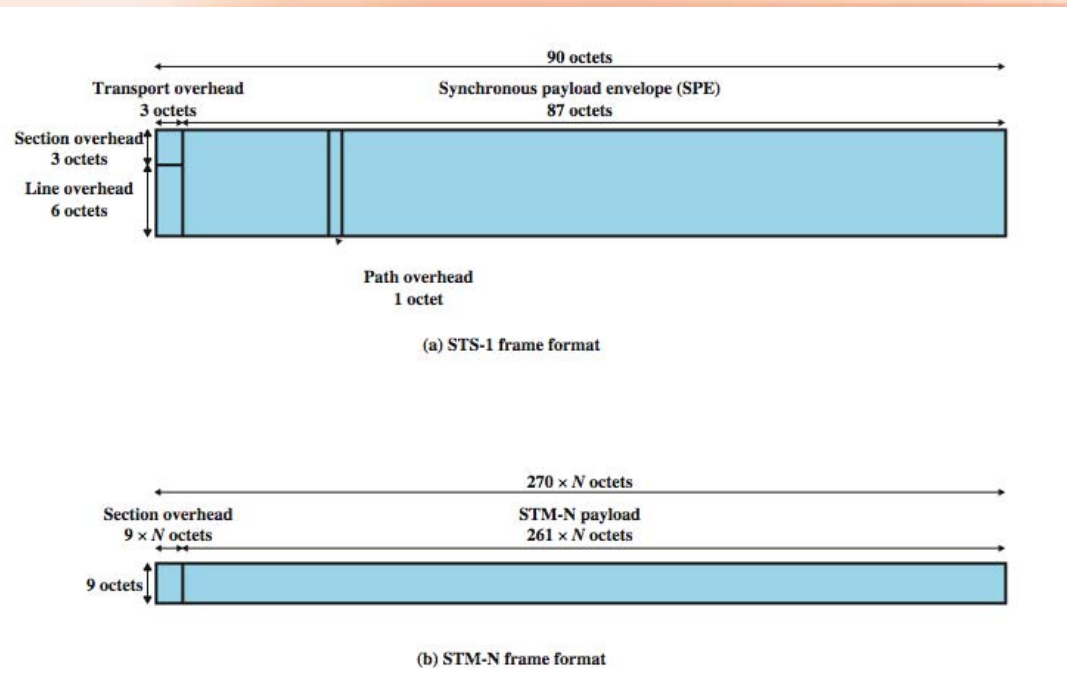

Statistical TDM

- in Synch TDM many slots are wasted
- Statistical TDM allocates time slots dynamically based on demand
- multiplexer scans input lines and collects data until frame full
- line data rate lower than aggregate input line rates
- may have problems during peak periods
 - must buffer inputs

Statistical TDM Frame Format

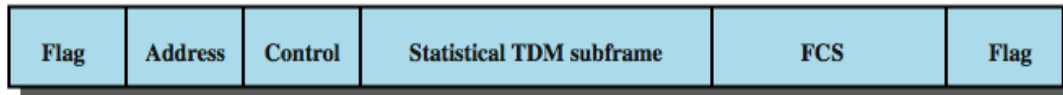

(a) Overall frame

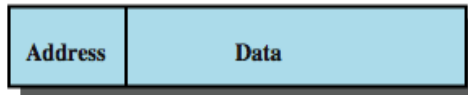

(b) Subframe with one source per frame

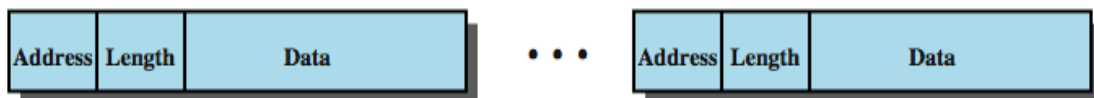

(c) Subframe with multiple sources per frame

Cable Modems

- dedicate two cable TV channels to data transfer
- each channel shared by number of subscribers, using statistical TDM
- Downstream
 - cable scheduler delivers data in small packets
 - active subscribers share downstream capacity
 - also allocates upstream time slots to subscribers
- Upstream
 - user requests timeslots on shared upstream channel
 - Headend scheduler notifies subscriber of slots to use

Cable Modem Scheme

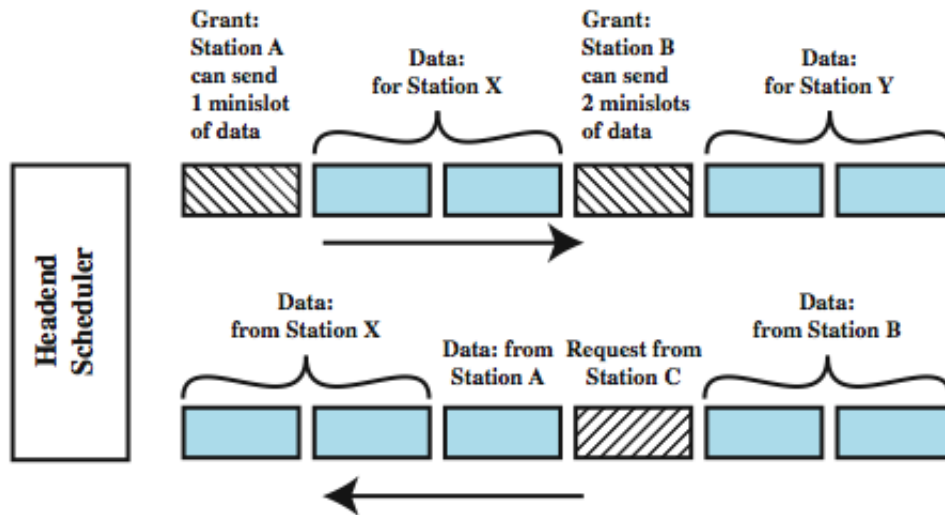

Asymmetrical Digital Subscriber Line (ADSL)

- link between subscriber and network
- uses currently installed twisted pair cable
- is Asymmetric - bigger downstream than up
- uses Frequency division multiplexing
 - reserve lowest 25kHz for voice (Plain old telephone service (POTS))
 - uses echo cancellation or FDM to give two bands
- has a range of up to 5.5km

ADSL Channel Configuration

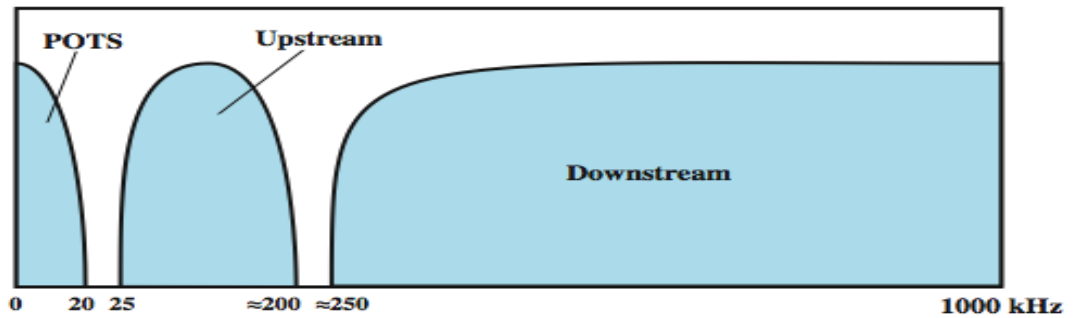

(a) Frequency-division multiplexing

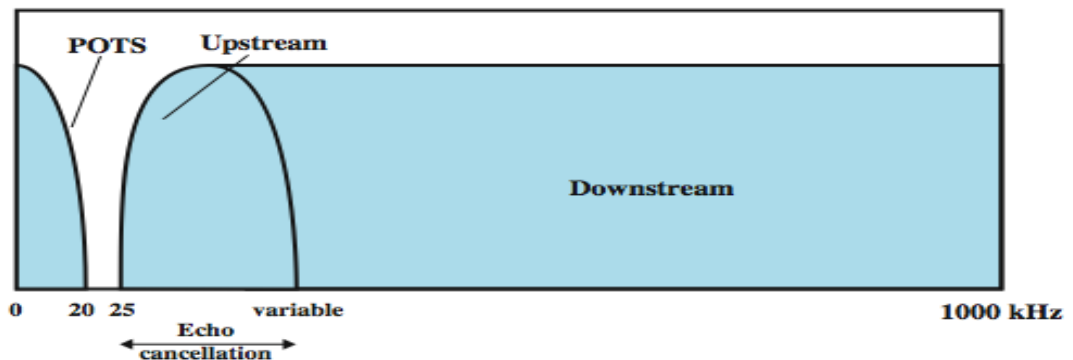

(b) Echo cancellation

Discrete Multitone (DMT)

- multiple carrier signals at different frequencies
- divide into 4kHz subchannels
- test and use subchannels with better SNR
- 256 downstream subchannels at 4kHz (60kbps)
 - in theory 15.36Mbps, in practice 1.5-9Mbps

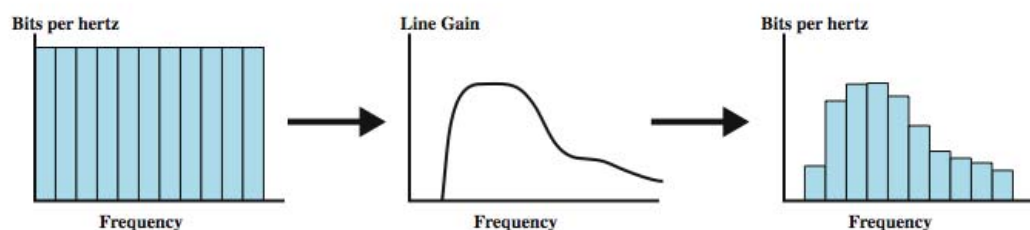

DMT Transmitter

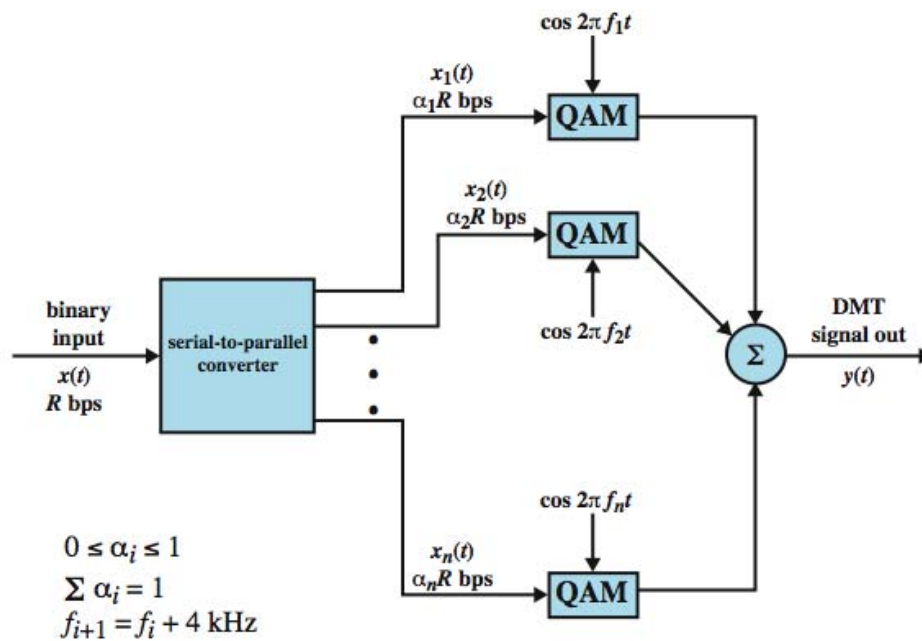

xDSL

- High data rate DSL (HDSL)
 - 2B1Q coding on dual twisted pairs
 - up to 2Mbps over 3.7km
- Single line DSL
 - 2B1Q coding on single twisted pair (residential) with echo cancelling
 - up to 2Mbps over 3.7km
- Very high data rate DSL
 - DMT/QAM for very high data rates
 - over separate bands for separate services

Summary

- looked at multiplexing multiple channels on a single link
- FDM
- TDM
- Statistical TDM
- ADSL and xDSL

Required Reading

**Data and Computer Communications,
10th Edition by William Stallings,
(c) Pearson Education - Prentice Hall, 2013**

**>> Chapter 8 –
Multiplexing**